

KOMATSU

AE50 Series

Model: FB15-12

FB15G-12

KOMATSU FORKLIFT

AE50 SERIES

● STANDARD SPECIFICATIONS

		Manufacturer's Designation		FB15-12	FB15G-12		
Characteristics	1.2	Model					
	1.3	Power Type	Electric, Diesel, Gasoline, LPG, Cable		Electric		
	1.4	Operation Type			Sitting		
	1.5	Rated Capacity	Q	Rated Capacity	kg	1500	
	1.6	Load Center	c	Rated Load Center	mm	500	
	1.6.1	Alternative Capacity	Q2	Capacity @600mm Load Center	kg	1350	
	1.8	Load Distance	x	Front Axle Center to Fork Face	mm	405	
	1.9	Wheelbase	y		mm	1410	1540
	Weight	2.1	Service Weight	Including Min. Capacity Battery, See line 6.5		kg	2930
2.2		Axle Loading	Loaded	Front	kg	3980	4040
2.2.1				Rear	kg	450	730
2.3			Unloaded	Front	kg	1490	1630
2.3.1				Rear	kg	1440	1640
Tyre	3.1	Tyre Type			Pneumatic		
	3.2	Tyre Size	Front		18x7-8-16PR(I)		
	3.3		Rear		16x6-8-10PR(I)		
	3.5	Number of Wheel	Front/Rear(x=driven)		2x/2		
	3.6	Tread, Front	b ₁₀	mm	940		
	3.7	Tread, Rear	b ₁₁	mm	865		
	4.1	Tilting Angle	α/β	Forward/Backward	degree	6/10	
Dimensions	4.2	Mast Height, Lowered	h ₁	2-stage Mast	mm	1995	
	4.3	Std. Free Lift	h ₂	2-stage Std. Mast from Ground	mm	140	
	4.4	Std. Lift Height	h ₃	2-stage Std. Mast from Ground	mm	3000	
	4.5	Mast Height, Extended	h ₄	2-stage Std. Mast	mm	3955	
	4.7	Height, Overhead Guard	h ₆		mm	2070	
	4.19	Length, with Std. Forks	l ₁		mm	2980	3115
	4.20	Length, to Fork Face	l ₂		mm	2060	2195
	4.21	Width, at Tyre	b ₁	Single	mm	1110	
	4.22	Forks	s/e/l	Thickness/Width/Length	mm	35x100x920	
	4.23	Fork Carriage Class	ISO 2328, Type A/B/no			Class 2, Type A	
	4.24	Width, Fork Carriage	b ₃		mm	970	
	4.31	Ground Clearance	m ₁	Under Mast	mm	95	
	4.32		m ₂	at Center of Wheelbase	mm	125	
	4.33	Right Angle Stacking Aisle	Ast	with L1000 x W1200 pallet	mm	3155*	3335*
	4.34		Ast	with L1200 x W800 pallet	mm	3355*	3535*
4.35	Turning Radius	Wa		mm	1750	1930	
Performance	5.1	Travel speed (FWD)	Loaded/Unloaded	km/h	15.0/17.0		
	5.2	Lifting Speed	Loaded/Unloaded	mm/s	340/600		
	5.3	Lowering Speed	Loaded/Unloaded	mm/s	450/550		
	5.6	Max. Drawbar Pull	Loaded, 3min, rating	N	9560		
	5.8	Max. Gradeability	Loaded, 3min, rating/1.5km/h	%	19	16	
	5.10	Service Brake	Operation/Control		Foot/Hydraulic		
	5.10.1	Parking Brake	Operation/Control		Hand/Mechanical		
5.10.2	Steering	Type		FHPS			
Drive	6.1	Drive Motor (AC)	60 min, rating	kW	4.5x2		
	6.2	Pump Motor (AC)	5 min, rating	kW	9.0		
	6.4	Battery Voltage		V	48		
	6.4.1	Battery Capacity, Min.		Ah/5hr	402	645	
	6.4.2	Battery Capacity, Max.		Ah/5hr	565	725	
6.5	Battery Weight	Min. capacity Battery, see line 6.4.1	kg	720	1000		
Others	8.1	Drive Motor Control			Transistor		
	8.2	Relief Pressure for Attachment			bar	176	
	8.2.1	Hydraulic Oil Capacity			Ltr	23	

*Add clearance

FB15-12, FB15G-12

● CAPACITY CHART

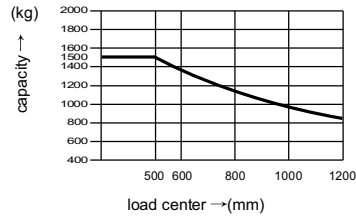

● DRAWING

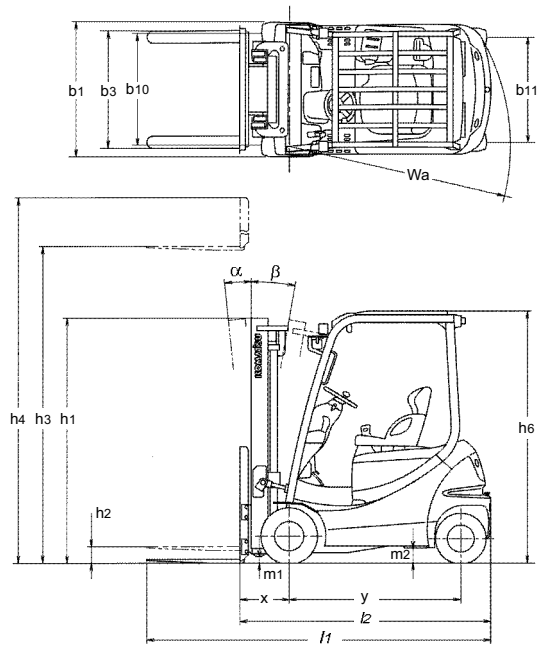

● STANDARD EQUIPMENT

- 3.0mH 2-stage free view mast
- Forks
- Load backerrest
- Ergonomic combination lever
- Side battery access
- Traveling/Lifting Operator Presence Sensing (OPS) system (ISO3691)
- Floor mat
- Assist grip
- Paper binder with pen tray
- Halogen headlight
- Back-up buzzer
- Fully hydrostatic power steering
- Wide angle center mirror
- HSS II seat with seat belt
- Intelligent Monitoring System (IMS)
- Adjustable individual setups
- Emergency switch
- Neutral safety mechanism
- High-mounted rear combination lamp

● OPTIONAL EQUIPMENT

- Protective resin head guard cover
- Digital load checker
- Automatic fork leveling device
- Softcarry (Hydraulic accumulator system)
- Front glass with wiper
- Anti rust coating paint
- Rear view mirror (Left & Right)
- Seat heater

AE50 SERIES

FB15-12, FB15G-12

● MAST SPECIFICATIONS

2-stage View Mast

*mark is the standard mast

Max. Fork Height	Overall Height			Free Lift		Tilting Angle Forward /Backward	Capacity at 600mm Load Center		Capacity at 500mm Load Center	Mast Weight
	Lowered	Extended		Without Load Backrest	With STD Load Backrest		FB15-12, FB15G-12			
		Without Load Backrest	With STD Load Backrest				Pneumatic Single Std. Tread	Elastic Cushion Std. Tread		
mm	mm	mm	mm	mm	mm	degree	kg		kg	
2700	1845	3285	3655	140		6/10	1350	1500	-15	
3000*	1995	3585	3955	140			1350	1500	305	
3300	2145	3885	4255	140			1350	1500	+15	
3500	2245	4085	4455	140			1350	1500	+30	
3700	2345	4285	4655	140			1350	1500	+70	
4000	2545	4585	4955	140			1350	1500	+100	
4300	2695	4885	5255	140		6/6	1300	1450	+115	
4500	2795	5085	5455	140			1300	1450	+125	
4700	2920	5285	5655	140			1210	1350	+140	
5000	3070	5585	5955	140			1210	1350	+160	

2-stage Full Free View Mast

Max. Fork Height	Overall Height			Free Lift		Tilting Angle Forward /Backward	Capacity at 600mm Load Center		Capacity at 500mm Load Center	Mast Weight
	Lowered	Extended		Without Load Backrest	With STD Load Backrest		FB15-12, FB15G-12			
		Without Load Backrest	With STD Load Backrest				Pneumatic Single Std. Tread	Elastic Cushion Std. Tread		
mm	mm	mm	mm	mm	mm	degree	kg		kg	
3000*	1995	3605	3975	1435	1065	6/10	1350	1500	340	
3300	2145	3905	4275	1585	1215		1350	1500	+20	
3500	2245	4105	4475	1685	1315		1350	1500	+30	
4000	2545	4605	4975	1985	1615		1350	1500	+90	

3-stage Full Free View Mast

Max. Fork Height	Overall Height			Free Lift		Tilting Angle Forward /Backward	Capacity at 600mm Load Center		Capacity at 500mm Load Center	Mast Weight	
	Lowered	Extended		Without Load Backrest	With STD Load Backrest		FB15-12, FB15G-12				
		Without Load Backrest	With STD Load Backrest				Pneumatic Single Std. Tread	Elastic Cushion Std. Tread			
mm	mm	mm	mm	mm	mm	degree	kg		kg		
3700	1795	4315	4685	1235	865	6/6	1350	1500	1350	1500	-35
4000	1895	4615	4985	1335	965		1300	1450	1300	1450	-20
4300*	1995	4915	5285	1435	1065		1260	1400	1260	1400	475
4500	2070	5115	5485	1510	1140		1170	1300	1210	1350	+15
4700	2145	5315	5685	1585	1215		1170	1300	1210	1350	+30
5000	2245	5615	5985	1685	1315		990	1100	1170	1300	+45
5500	2420	6115	6485	1860	1490		900	1000	1170	1300	+75
6000	2595	6615	6985	2030	1665		720	800	1030	1150	+145

Note: With 3-stage Full Free View Mast tilt speed will be reduced by restricting tilt lever speed.