

KOMATSU

EX50 SERIES

Model: FD100-8

KOMATSU FORKLIFT

000 / 0707

EX50 SERIES

● **STANDARD SPECIFICATIONS**

Characteristics	1.2	Model	Manufacturer's Designation		FD100-8	
	1.3	Power Type	Electric, Diesel, Gasoline, LPG, Cable		Diesel	
	1.4	Operation Type			Sitting	
	1.5	Rated Capacity	Q	kg(lb)	10000(22,000)	
	1.6	Load Center	c	mm(in)	600(24)	
	1.8	Load Distance	x	Front Axle Center to Fork Face	mm(in)	695(27.4)
	1.9	Wheelbase	y	mm(in)	2800(110.2)	
	Weight	2.1	Service Weight		kg(lb)	12980(28,620)
		2.2	Axle Loading	Loaded	Front	kg(lb)
2.2.1		Rear			kg(lb)	2120(4,670)
2.3		Unloaded		Front	kg(lb)	6230(13,730)
2.3.1				Rear	kg(lb)	6750(14,880)
Tyre	3.1	Tyre Type			Pneumatic	
	3.2	Tyre Size	Front		9.00-20-14PR(I)	
	3.3		Rear		9.00-20-14PR(I)	
	3.5	Number of Wheels	Front/Rear(x=driven)		4x/2	
	3.6	Tread, Front	b ₁₀	mm(in)	1700(66.9)	
	3.7	Tread, Rear	b ₁₁	mm(in)	1900(74.8)	
	Dimensions	4.1	Tilting Angle	α/β	Forward/Backward	degree
4.2		Mast Height, Lowered	h ₁	2-stage Std. Mast	mm(in)	2890(113.8)
4.3		Std. Free Lift	h ₂	2-stage Std. Mast from Ground	mm(in)	0(0.0)
4.4		Std. Lift Height	h ₃	2-stage Std. Mast from Ground	mm(in)	3000(118)
4.5		Mast Height, Extended	h ₄	2-stage Std. Mast	mm(in)	4400(173.2)
4.7		Height, Overhead Guard	h ₆		mm(in)	2780(109.4)
4.19		Length, with Std. Forks	L ₁		mm(in)	5465(215.2)
4.20		Length, to Fork Face	L ₂		mm(in)	4245(167.1)
4.21		Width, at Tyre	b ₁	Single	mm(in)	2280(89.8)
4.22		Forks	s/e/l	Thickness/Width/Length	mm(in)	75x170x1220(3.0x6.7x48.0)
4.23		Fork Carriage Class				Pin Mount
4.24		Width, Fork Carriage	b ₂		mm(in)	2140(84.3)
4.31		Ground Clearance	m ₁	Under Mast	mm(in)	250(9.8)
4.32			m ₂	at Center of Wheelbase	mm(in)	325(12.8)
4.33		Right Angle Stacking Aisle	Ast	Add load length and clearance	mm(in)	4695(184.8)
4.35	Turning Radius	Wa		mm(in)	4000(157.5)	
Performance	5.1	Travel Speed (FWD)	Loaded, 1st/2nd/3rd	km/h(mph)	8.5/18/28(5.3/11.2/17.4)	
	5.1.1		Unloaded, 1st/2nd/3rd	km/h(mph)	9/20/32(5.6/12.4/19.9)	
	5.2	Lifting Speed	Loaded/Unloaded	mm/s(fpm)	470/500(93/98)	
	5.3	Lowering Speed	Loaded/Unloaded	mm/s(fpm)	400/500(79/98)	
	5.6	Max. Drawbar Pull	Loaded, 1.5km/h, 3min rating	KN(lb)	89(20,010)	
	5.8	Max. Gradeability	Loaded, 1.5km/h, 3min rating	%	40	
	5.10	Service Brake	Operation/Control		Foot/Hydraulic, Powered	
	5.11	Parking Brake	Operation/Control		Hand/Mechanical	
5.12	Steering	Type		Hydraulic Power Steering		
6.4	Battery	Voltage/Capacity at 5-hour rating		V/Ah	24/80	
I.C. Engine	7.1	Make / Model			KOMATSU SAA6D107E-1	
	7.2	Rated Output, SAE net			KW(HP)	122(164)
	7.3	Rated RPM			min ⁻¹	2200
	7.3.1	Max. Torque, SAE net			Nm@min ⁻¹	575(424)@1600
	7.4	No. of Cylinders/Displacement			cm ³ (cu.in)	6/6690(408)
	7.6	Fuel Tank Capacity			Ltr(US Gal)	260(69)
Others	8.2	Relief Pressure for Attachment			bar(psi)	216(3,100)
	8.2.1	Hydraulic Tank Capacity			Ltr(US Gal)	180(48)
	8.6	Clutch				Torque Converter
	8.7	Transmission				TORQFLOW

FD100-8

● CAPACITY CHART

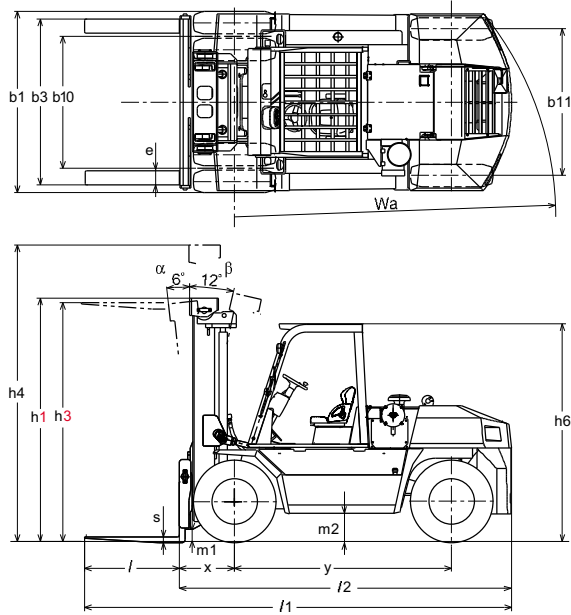
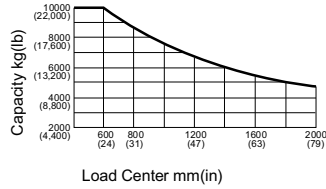

● STANDARD EQUIPMENT

- Headlights
- Rear view mirror
- Turn signal lamps
- Charge warning lamps
- Safety checker
- Hourmeter
- Fuel gauge
- Torque converter oil temperature gauge
- Water temperature gauge
- Neutral safety switch
- Brake oil pressure warning buzzer
- Torque converter oil cooler
- Tiltable steering column
- Hydraulic power brake
- Horn
- Overhead guard
- Drawbar pin
- Cyclonic air cleaner
- Notch-release parking brake
- Back-up buzzer

● OPTIONAL EQUIPMENT

- Automatic Transmission
- Wet disk brake
- Operator Presence Sensing (OPS) system
- UL specification
- Cold climate specification (-30 degree)
- Rotating light
- Rear working light
- Speedometer
- Load indicator
- Special length forks
- Extension forks
- Air cleaner with pre-cleaner
- Spark arrester
- Rear under mirror
- Steel cabin
- Air conditioner
- Heater
- Rotating seat
- Fuel cap with key

● ATTACHMENT

- Side shifter
- Side shift fork positioner (Independent move)
- Fork positioner (Independent move)
- Fork positioner with side shift function (Simultaneous move)
- Manipulator*
- Ram*
- Crane*
- Pole carrier fork*
- Furnace charger*
- Tyre handler*

*: Available upon request

EX50 SERIES

● **MAST SELECTION**

2-stage Free View Mast

* mark is the standard mast

Max. Fork Height	Overall Height		Free Lift	Tilting Angle		Capacity at 600mm(24") Load Center	Mast Weight
	Lowered	Extended		Forward	Backward	FD100-8	
						Front Double Tyre	
	mm(in)	mm(in)		mm(in)	mm(in)	degree	
2800(110)	2790(111.8)	4200(165.4)	0(0)	6	12	10000(22,000)	-50(-110)
3000(118)*	2890(113.8)	4400(173.2)	0(0)	6	12	10000(22,000)	2530(5,570)
3300(130)	3040(119.7)	4700(185.0)	0(0)	6	12	10000(22,000)	+60(+130)
3500(138)	3140(123.6)	4900(192.9)	0(0)	6	12	10000(22,000)	+110(+240)
3700(146)	3240(127.6)	5100(200.8)	0(0)	6	12	10000(22,000)	+150(+330)
4000(157)	3390(133.5)	5400(212.6)	0(0)	6	12	10000(22,000)	+260(+570)
4500(177)	3740(147.2)	6000(236.2)	0(0)	6	12	10000(22,000)	+410(+905)
5000(197)	4140(163.0)	6650(261.8)	0(0)	6	12	10000(22,000)	+620(+1,370)
5500(217)	4440(174.8)	7200(283.5)	0(0)	6	12	9000(19,800)	+770(+1,690)
6000(236)	4690(184.6)	7700(303.1)	0(0)	6	12	8000(17,600)	+880(+1,940)